

Types of Relays



—
&
—

**UNIVERSITY
CENTRE**

Electromechanical Relay

- An electromechanical relay is the standard type of relay relying on magnetic fields and moving contacts to complete circuits
- Typically used in industrial control panels, HVAC systems and general switching
- Its advantages are its simple, cheap and easy to troubleshoot
- Its disadvantages are contact wear and slower switching than other types

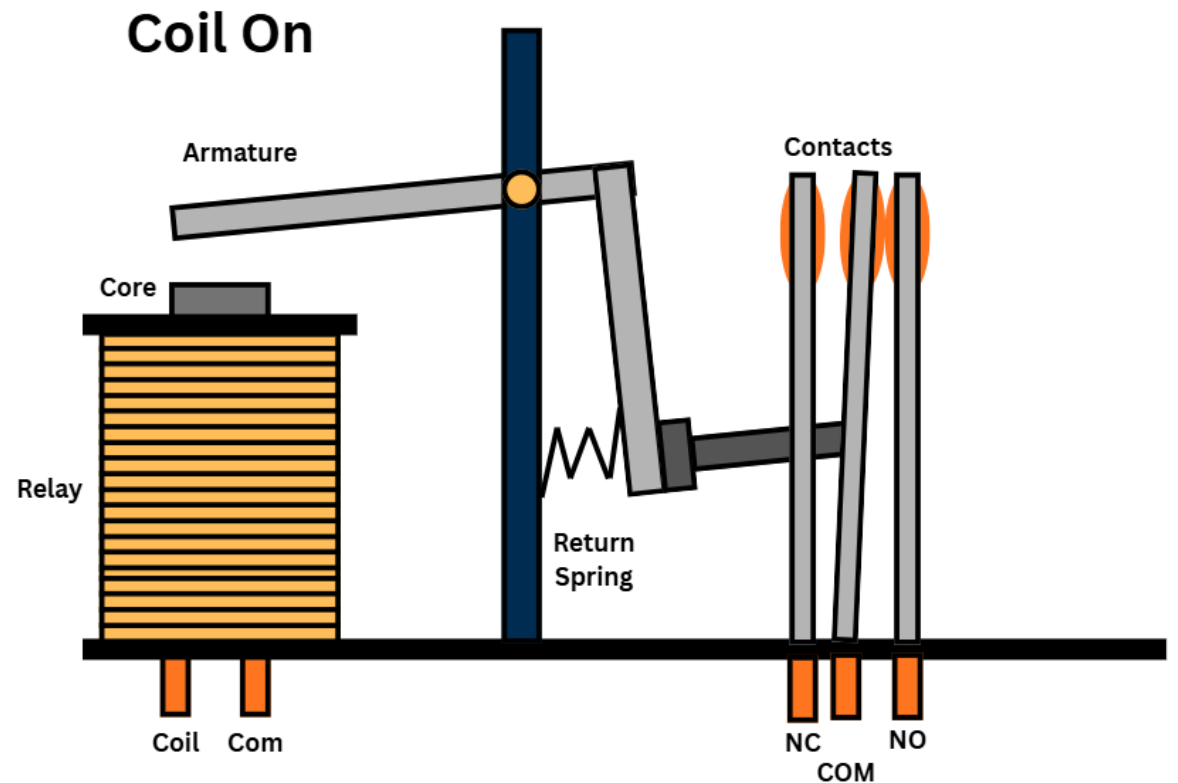

Reed Relay

- A reed relay uses magnetic reeds (thin sturdy strips of metal) sealed in a glass tube
- Typically used in instrumentation, test equipment and signal switching
- Its advantages are its very small, reliable and have a long life
- Its disadvantages are contact wear and limited power handling

NO AXIAL FIELD

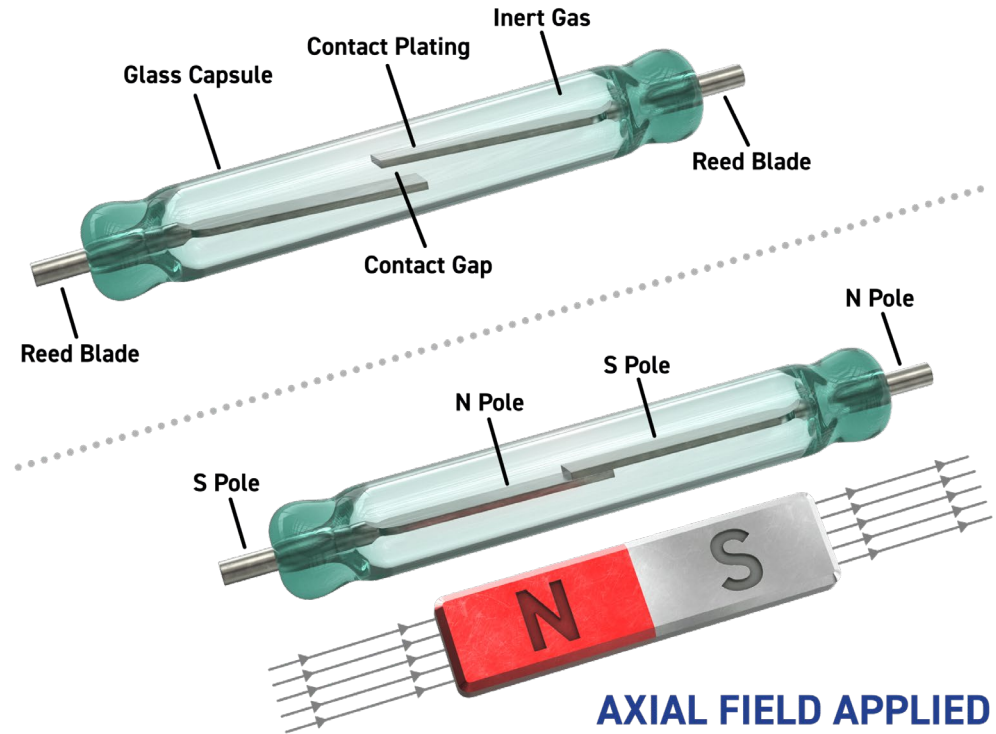

Solid State Relay

- A solid-state relay is a relay with no moving parts using semiconductor devices for switching
- Typically used in heating systems, PLC outputs and fast switching circuits
- Its advantages are its no contact bounce, durable, high cycle life
- Its disadvantages are heat generation, leakage current and more expensive

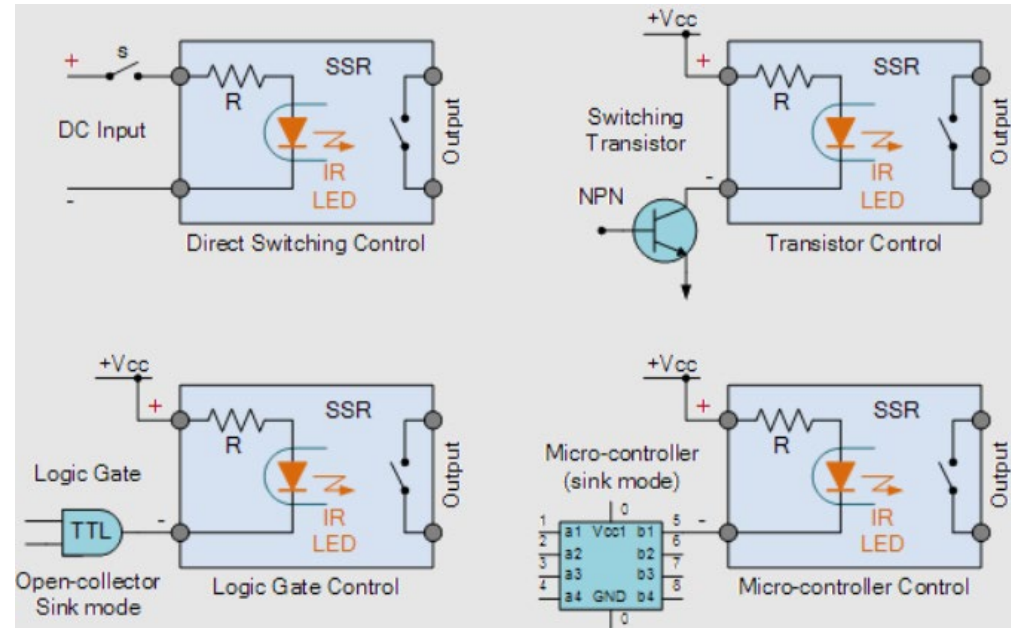

Safety Relay

- A relay designed specifically to monitor safety circuits and ensure fail-safe operation
- They feature redundant contacts as well as self monitoring and detection of wiring faults capabilities
- Typically used in machine guarding, emergency stop systems, safety gates and light curtains
- Its advantages are it improves operator safety, meets safety regulations and is capable of fault detection
- Its disadvantages are its more complex and more expensive



Using a Safety Relay

- A safety relay is used to monitor safety-critical devices and ensure machinery enters a safe state if a fault or dangerous condition occurs
- They typically respond to two failure modes:
 - Contact is closed while it should be opened
 - Contact is open while it should close
- These modes are typically caused by mechanical defects or welded or burnt contacts.
- The safety relay appropriately responds to the failure and ensures that the circuit properly enters a safe idle mode

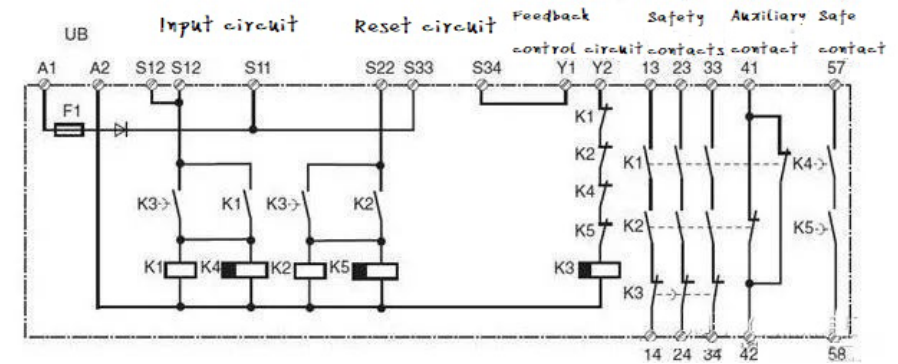

Using a Safety Relay

- A safety relay uses a dual channel system which uses two independent signal paths that are monitored simultaneously. This gives redundancy and fault detection.
- For example, in an e-stop:
 - Channel 1 = first normally closed contact from the E-stop
 - Channel 2 = second independent normally closed contact from the same E-stop
- The safety relay expects both channels to behave correctly and change state together.
- If only one channel changes, the relay assumes a fault exists.

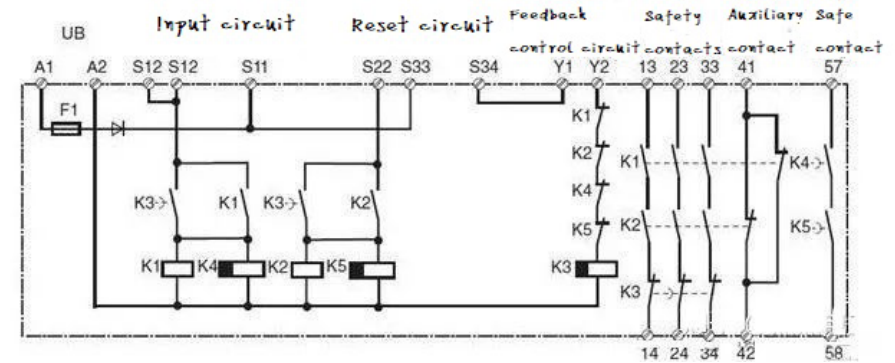

Using a Safety Relay vs Standard Relay

- Standard Relay Limitations:

- Designed for switching only.
- Does not monitor faults.
- No redundancy.
- Cannot detect welded contacts.
- May allow unsafe restart after failure.
- Single fault could leave dangerous equipment running.

- Safety Relay Advantages:

- Built specifically for safety-critical systems.
- Uses dual-channel monitoring.
- Detects wiring faults and contact failures.
- Includes self-monitoring diagnostics.
- Prevents unexpected machine restart.
- Designed to fail into a safe state.

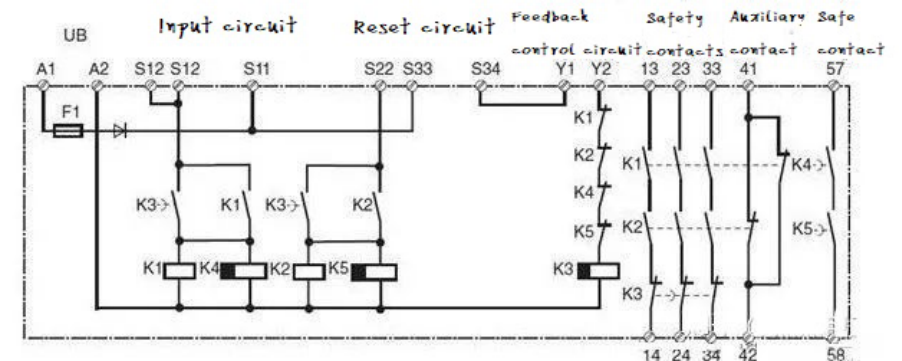

Time Delay Relays

- A relay that switches after a preset delay being either On-delay, Off-delay or Pulse.
- On delay turns on a set time after an input signal
- Off delay turns off a set time after the loss of an input signal
- Pulse delay turns on for a set amount of time when receiving an input signal before turning off
- Typically used in motor starting sequences, conveyor systems and lighting control
- Its advantages are it allows sequences and reduces sudden startup times
- Its disadvantages are that it requires additional setup

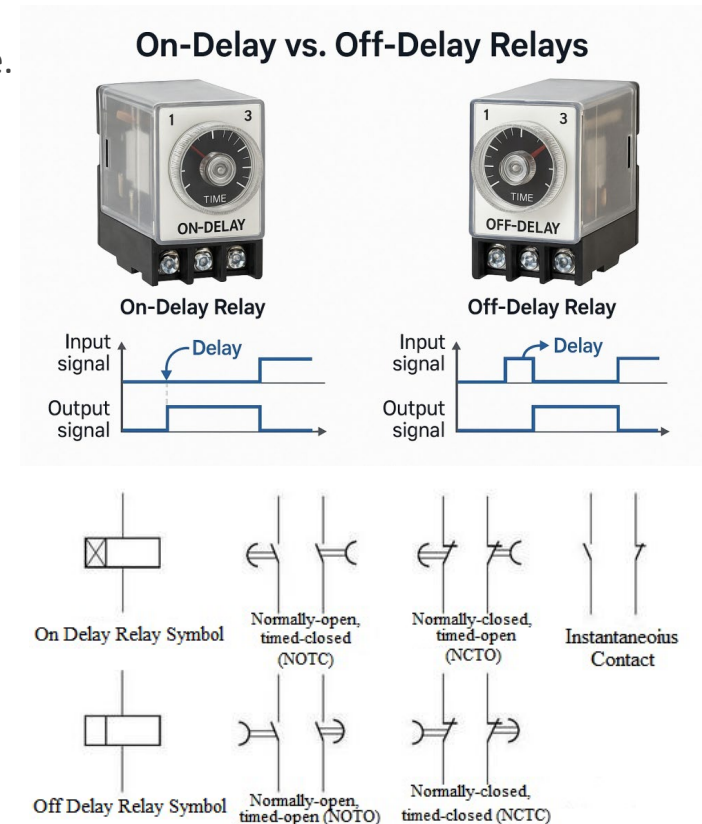

Latching Relays

- A relay that remains in its last position after power is removed
- It typically features both a set and a reset for turning it on and off
- It has a memory effect, remembering its last inputs, it requires just a pulse to switch states, and it reduces energy use
- Its typical applications are lighting systems, battery powered devices and smart controls
- Its advantages are low power consumption and its ability to maintain its state during power loss
- Its disadvantage is that its more complex to control and work with

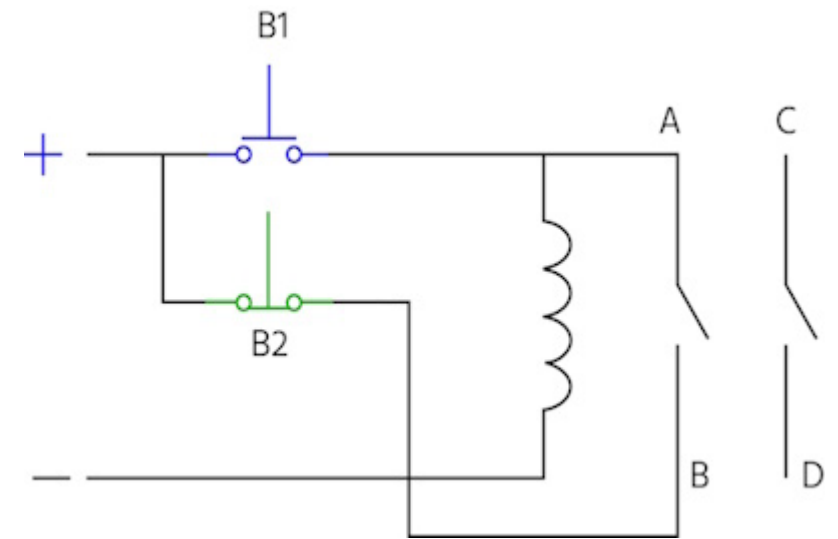
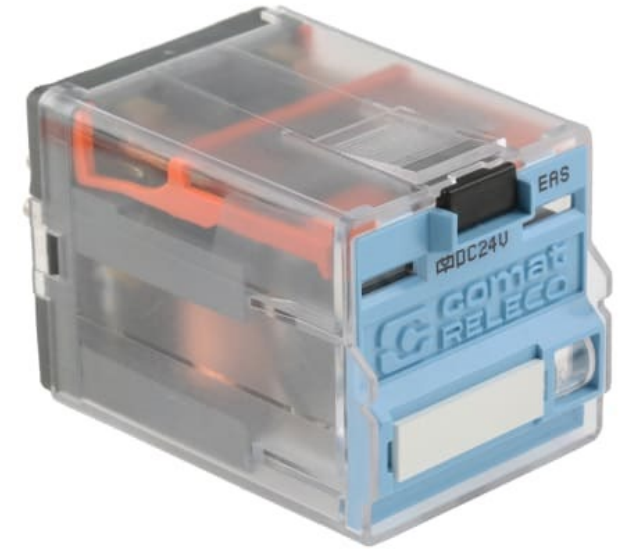

Thermal Overload Relays

- A relay that is designed to stop components (mainly motors) from overheating
- It relies on the principles of thermal expansion, when the bimetal strip is heated it deforms allowing the NO contacts to touch giving an output
- It trips under excessive current as the heating coil gets too warm
- Typically used in motor protection and industrial machinery
- Its advantages are it prevents motor damage and provides reliable protection
- However, it cannot be used for instant short-circuit protection as it takes time for the metal to deform

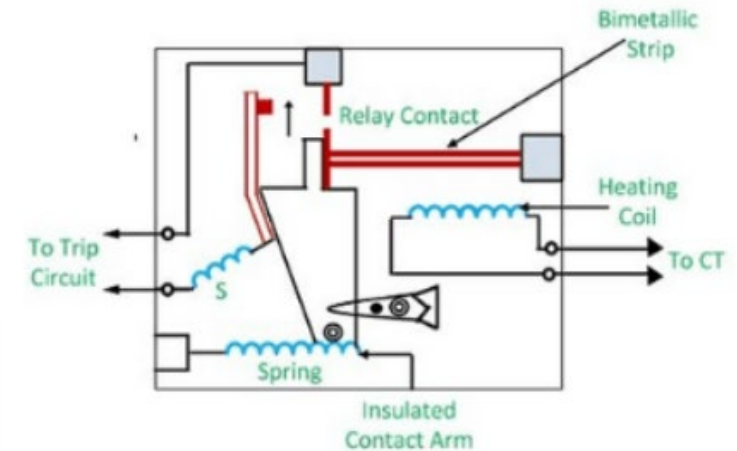
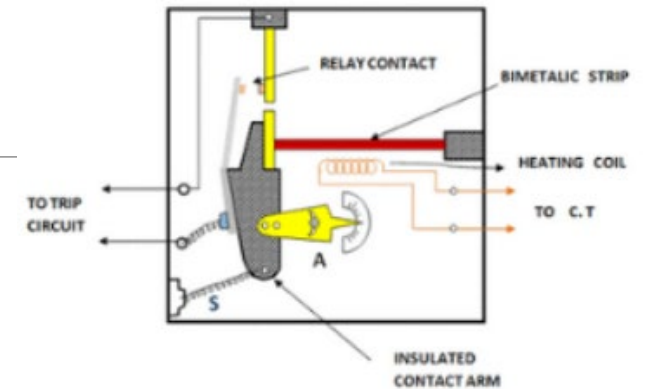

Protective Relays

- A relay is used in power systems to detect faults and isolate equipment
- Has 4 main types:
 - Over current
 - Earth Fault
 - Differential
 - Distance
- Typically used in electrical substations, power distribution and generator protection
- Its advantages are it prevents equipment damage and improves system stability
- Its main disadvantage is it require calibration to work properly



Table of relays

Relay Type	Moving Parts	Speed	Typical Use
Electromechanical	Yes	Medium	General switching
Reed	Yes	Fast	Signal switching
Solid State	No	Very Fast	PLC outputs/heating
Safety	Yes	Medium	Machine protection
Time Delay	Yes	Medium	Sequencing
Latching	Yes	Medium	Memory switching
Thermal Overload	Yes	Slow	Motor protection
Protective	Varies	Fast	Power systems